

Design fan coil unit with a minimum depth of 10 cm only and BLDC motor

ART-U 1 - 4 kW

Available from SEPTEMBER 2018



BLDC motor



Tangential fan



Supervision ERGO



2 pipes systems



Vertical installation

PLUS

- » Unit with an innovative design and depth down to only 10 cm
- » Inverter-controlled BLDC motor
- » Low energy consumption
- » Modulating operation

Design-driven innovation

From the extensive experience of Galletti in the development and design of fan coil units, and in confirmation of its continuous search for innovation, has been created ART-U, the result of a perfect combination of performance and design.

The goal achieved by this project is absolutely ambitious: a new and unique product, not yet present on the market, which on the one hand is able to meet the increasingly stringent demands for energy efficiency, and, on the other hand, for the first time, reflect the latest trends in furnishings and interior design. With the new ART-U, this goal has been fully achieved, presenting on the market a new concept of hydronic indoor unit, a product that is characterized by its enviable technical performance and at the same time represents a true style shift in a field that has long been dominated by products that are all very similar to each other.

ART-U, with its depth down to only 10 cm, and thanks to its unique lines, was designed to be an absolutely all-purpose product, that adapts perfectly to rigorous and essential environments as well as to warmer and more sophisticated spaces. Thanks also to the possibility of customizing the front panel, ART-U meets the demand for ever more personalization of the spaces to be furnished. The achievement of extremely high aesthetic standards has not weakened the usual construction integrity of Galletti products: striving for innovation has in fact also focused on the components and the use of new materials. With ART-U the state of the art has been redefined also in terms of technical performance, thanks to the use of computational fluid dynamics simulations for the optimisation of the heat exchange inside the indoor unit combined with the use of permanent magnet electric motors.



MAIN COMPONENTS
Cabinet with a refined design

The elegant front panel consists of two sheets of aluminium with a polyethylene core and possibly a polyester-based surface coating. It is a light but very resistant material, created for covering façades in the building sector. The side panels are made of UV-stabilized ABS to maintain the colour over time. The polyethylene core acts as a flexible filler and thermal insulation while the aluminium provides structural strength and aesthetics.

Conveyors

Made of high-density polystyrene. They are designed to optimise the air flow inside the hydronic indoor unit allowing optimal distribution of the air flow in the coil and low noise in every operating mode.

Upper grille

Consisting of adjustable fins made of anodised aluminium, available in the version for on-board or wall-mounted control. The ABS combs support the grilles and prevent them from being bent, thus always guaranteeing the user's safety.

Front grille

Stabilizes the operation of the tangential fan unit and is equipped with a stainless steel filter.

Electric motor

Permanent magnet BLDC motor with inverter integrated in the ventilation unit. An IP54 protection rating is guaranteed; therefore, dust inside is avoided and resistance to water spray is guaranteed.

Tangential fans

Tangential fan, statically and dynamically balanced to reduce its noise during operation. The plastic material used for the blades guarantees, in comparison with metal fans, a reduction in vibrations and an absence of bending along the rotation axis. The blades are alternated with intermediate reinforcement disks in order to increase their sturdiness.

Heat exchangers

With high efficiency turbocoil-type heat exchanger, and made with copper tubing and aluminium fins, it is equipped with brass manifolds and a vent valve. The hydrophilic treatment is applied to the fins as a standard treatment, to increase their efficiency during cooling while at the same time providing greater resistance to aggressive environments. The water connections are reversible during installation. On request it is possible to mount an additional heat exchanger for 4-pipe systems.

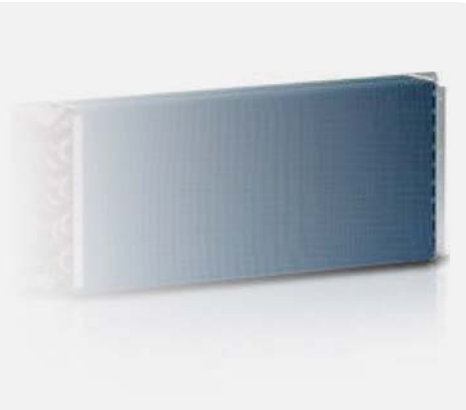
Air filter

Honey-comb polypropylene washable filter, easily removable for maintenance operations.

AVAILABLE VERSIONS



ART-U Grey

The front panel made of brushed aluminium, combined with black side panels, was designed to enhance the reduced depth of the fan coil. The product, with simple, clean, and essential lines, fits perfectly in environments whose furnishings follows new trends and where a high level of design is required for each item.



ART-U White

The neutrality of the white ensures maximum integration with the space in an adaptive context, allowing the fan coil unit to almost disappear into the wall.

ART-U it can be customized with different color variations upon request.

COMPUTATIONAL FLUID DYNAMICS SIMULATIONS
The model

Computational Fluid Dynamics (CFD) is a method that uses numerical analysis to solve the problems of fluid dynamics by using computers.

For the ART-U project it was considered a computational domain discretized by means of a polyhedral calculation grid (mesh) consisting of 12 million cells.

The mesh has a refinement that extends to the entire rotor area to better reproduce the vorticity that is created in that area.

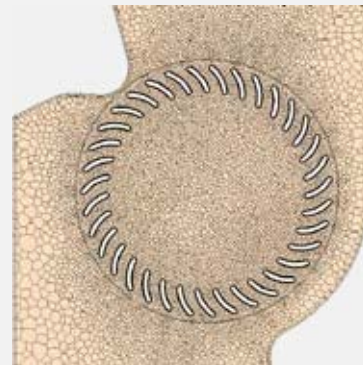
Air motion field

During the initial phase of development of the ART-U project the calculation showed the recirculation of the fluid downstream of the rotor in different areas, with consequent water pressure drop.

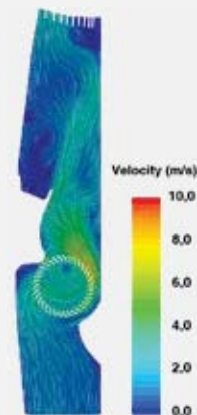
Flow lines

The flow lines show how the trajectory of the threads of liquid inside the unit does not have a uniform distribution.

For this reason, the research has also focused on improving the air distribution along the longitudinal axis of the fan unit, minimizing the wall interference effects.

The results of these simulations have allowed an optimisation of the geometry of the internal conveyor and the orientation of the finned block coil.

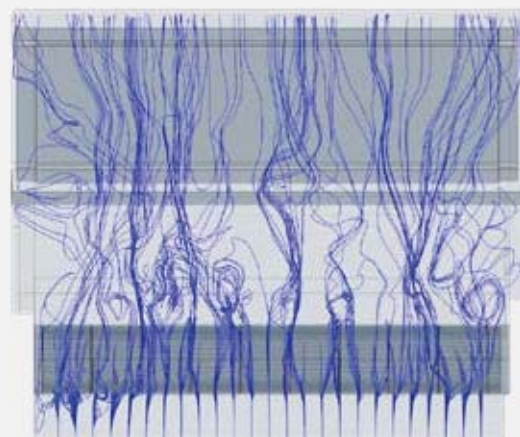

The final benefit obtained from the CFD simulations performed is a further improvement in the heat exchange, with a consequent reduction in power consumption and noise emissions with the same components and under the same operating conditions.

ACCESSORIES

EVOBOARD	Circuit board for EVO control	TED SWA	Water temperature sensor for TED controls
EVODISP	User interface with display for EVO controller	BV	Auxiliary water drip tray for vertical installation fan coil units
KBEVS	EVO on-board installation Kit for ART-U	GIVK	Insulating shell for VKS valve
MCLE	Microprocessor control with display MY COMFORT LARGE	PV	Rear painted panel for vertical installation with cabinet
MCSUE	Humidity sensor for MY COMFORT (medium e large), EVO	V2VSTD	2-way valve, ON/OFF or MODULATING actuator, 230 V or 24 V power supply, hydraulic kit, for main heat exchanger
MCSWE	Water sensor for MYCOMFORT, EVO, LED 503 controllers	V3VSTD	2-way valves, ON/OFF or MODULATING actuator, 230 V or 24 V power supply, hydraulic kit, for main heat exchanger
KBTES	On-board ART-U installation kit suitable for TED controller		
TED 10	Electronic controller for BLDC fan equipped with inverter and ON/OFF valves 230 V		

RATED TECHNICAL DATA

ART-U			10			20			30		
Speed			min	med	max	min	med	max	min	med	max
Control voltage		V	4,50	5,70	6,40	4,90	7,00	10,0	5,40	7,00	10,0
Total cooling capacity	(1)	kW	0,39	0,69	0,80	0,93	1,32	1,67	1,44	2,01	2,44
Sensible cooling capacity	(1)	kW	0,29	0,50	0,63	0,69	0,99	1,28	1,05	1,44	1,84
Total cooling capacity	(2)	kW	0,39	0,69	0,80	0,93	1,31	1,66	1,43	2,00	2,42
Sensible cooling capacity	(2)	kW	0,29	0,49	0,62	0,68	0,98	1,26	1,04	1,43	1,82
FCEER class			C			B			B		
Water flow	(1)	l/h	67	116	134	161	227	282	247	329	395
Water pressure drop	(1)	kPa	3	1	2	4	8	11	12	20	27
Heating capacity	(3)	kW	0,56	0,73	0,87	1,04	1,38	1,81	1,52	2,09	2,48
FCCOP class			C								
Water flow	(3)	l/h	98	126	146	169	238	303	261	413	413
Water pressure drop	(3)	kPa	3	1	2	4	7	12	11	20	27
Rated air flow		m ³ /h	110	141	179	190	275	391	295	390	528
Power input		W	4	5	6	7	11	17	10	14	23
Total sound power level		dB(A)	37	44	49	39	47	54	41	47	54

ART-U			40			50		
Speed			min	med	max	min	med	max
Control voltage		V	5,50	7,00	10,0	5,50	7,00	10,0
Total cooling capacity	(1)	kW	1,96	2,62	3,16	2,29	3,17	3,72
Sensible cooling capacity	(1)	kW	1,43	1,97	2,43	1,66	2,26	2,83
Total cooling capacity	(2)	kW	1,95	2,60	3,13	2,28	3,14	3,69
Sensible cooling capacity	(2)	kW	1,42	1,95	2,39	1,65	2,24	2,79
FCEER class			B			B		
Water flow	(1)	l/h	338	441	528	395	517	622
Water pressure drop	(1)	kPa	9	15	20	14	23	31
Heating capacity	(3)	kW	1,96	2,66	3,34	2,49	3,07	3,74
FCCOP class			C					
Water flow	(3)	l/h	360	457	557	416	528	644
Water pressure drop	(3)	kPa	8	14	20	14	20	28
Rated air flow		m ³ /h	412	529	715	474	609	824
Power input		W	14	20	32	16	23	36
Total sound power level		dB(A)	42	47	54	42	47	54

(1) Water temperature 7°C / 12°C, air temperature dry bulb 27°C, wet bulb 19°C (47% relative humidity)

(2) According to EN1397:2015

(3) Water temperature 45°C / 40°C, air temperature 20°C

Power supply 230-1-50 (V-ph-Hz)

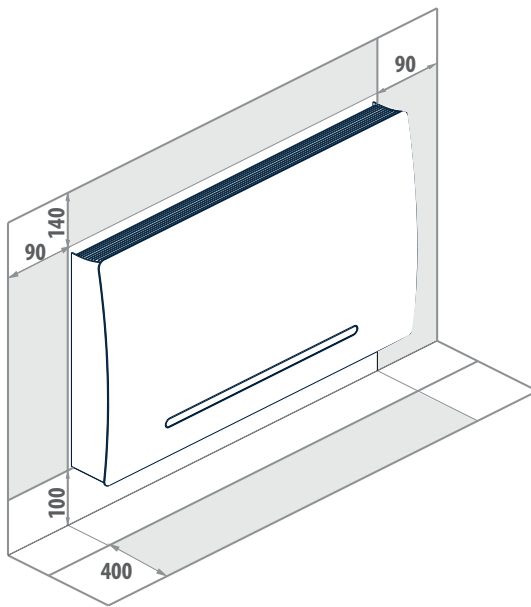
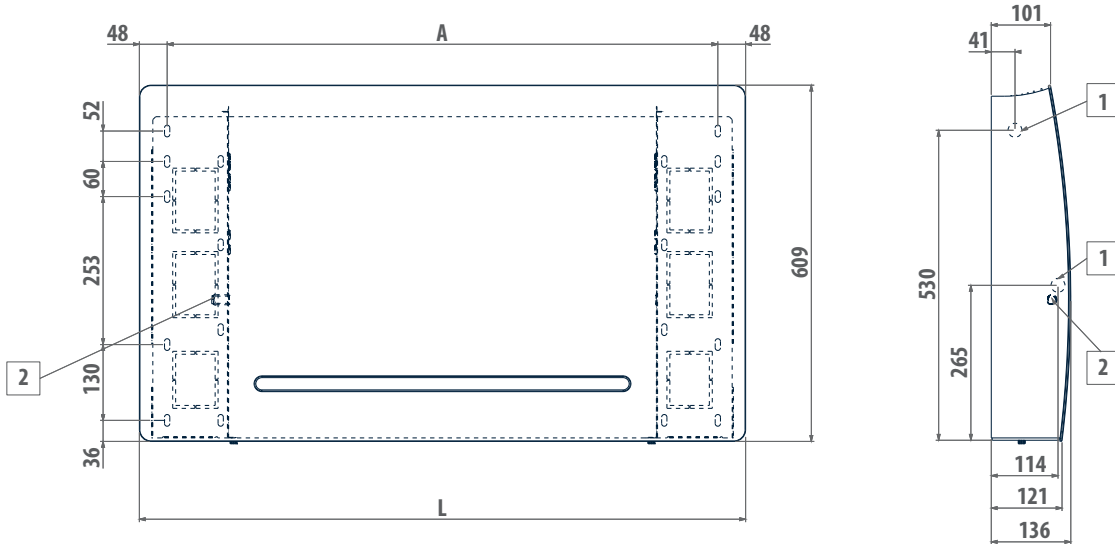
DIMENSIONAL DRAWINGS
ART-U

LEGEND

- | | |
|----------|--|
| 1 | Water connections standard heat exchanger ϕ 1/2" |
| 2 | Condensate discharge diameter for vertical installation ϕ 17 mm |

Mod.	A mm	L mm	 kg
ART-U 010	616	711	12
ART-U 020	772	867	14
ART-U 030	941	1036	17
ART-U 040	1173	1268	19
ART-U 050	1307	1402	21